

UNION ELBOW
MODEL CODE : KEU

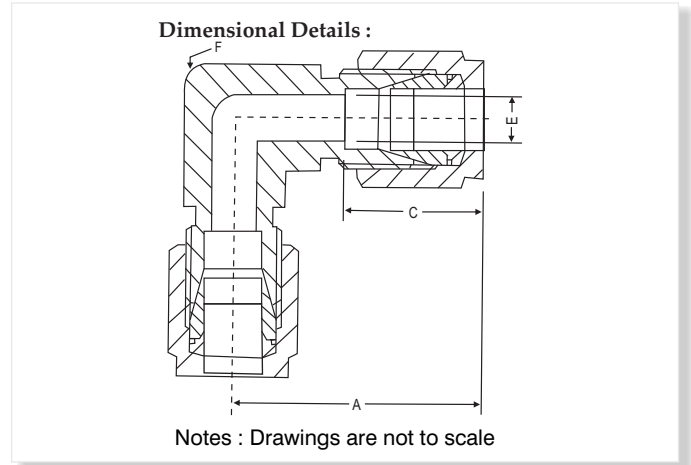

HOW TO ORDER

Dimension, in.

Tube OD	Part Number	A	C	E	F
1/8	KS2EU2	0.88	0.50	0.09	3/8
1/4	KS4EU4	1.06	0.60	0.19	1/2
3/8	KS6EU6	1.20	0.66	0.28	5/8
1/2	KS8EU8	1.42	0.90	0.41	13/16
5/8	KS10EU10	1.50	0.96	0.50	15/16
3/4	KS12EU12	1.57	0.96	0.62	1 1/16
7/8	KS14EU14	1.76	1.02	0.72	1 3/8
1	KS16EU16	1.93	1.23	0.88	1 3/8

Dimension, mm.

Tube OD	Part Number	A	C	E	F
6	KSM6EU	27.0	15.3	4.8	1/2
8	KSM6EU	28.8	16.2	6.4	9/16
10	KSM10EU	31.5	17.2	7.9	11/16
12	KSM12EU	36.0	22.8	9.5	13/16
16	KSM16EU	38.0	24.4	12.7	15/16
18	KSM18EU	39.8	24.4	15.1	1 1/16
20	KSM20EU	44.6	26.0	15.9	1 3/8
25	KSM25EU	49.1	31.3	21.8	1 3/8

Dimensions and specifications shown are approximate, may vary from time to time.

Note : A and C dimensions are typical finger-tight

Compression tube fittings are ordered by part numbers as listed in this catalogue and other sizes will be available on request.

FOR OTHER OPTIONAL ITEMS, PLEASE CONTACT FACTORY FOR DELIVERY AND MINIMUM QUANTITY OF ORDER.

Note : Specifications and dimensions given in this product catalogue represents the state of engineering at the time of printing.

Modifications may take place and materials specified may be replaced by others without prior notice.